

Installation

LVGD3

Verge® Lavatory System – LVGD-Series
with Evero® Natural Quartz Material

Table of Contents

Components	2
Supplies Required	3
Dimensions	3-4
Rough-Ins	5
Frame Mounting	6
Drain Assembly	7
Faucets and Optional Soap Valve	7
Bowl Mounting	8
Strainer and P-Trap	9
Adjust the Temperature	9
Trap Cover	10
Multi-Feed Tank System	11
Cleaning and Maintenance	12

WARNING

Turn OFF electrical power to the electrical outlets, then unplug all electrical units prior to installation. Electrical power MUST remain off until installation is complete.

Installer's hardware must be appropriate for wall construction. Wall anchors must have a minimum pull-out rating of 1,000 lb.

NOTICE

Make sure that all water supply lines have been flushed and then completely turned off before beginning installation. Debris in supply lines can cause valves to malfunction.

IMPORTANT

Read this entire installation manual to ensure proper installation. When finished with the installation, file this manual with the owner or maintenance department. Compliance and conformity to local codes and ordinances is the responsibility of the installer. Product warranties may be found under "Products" on our Web site at bradleycorp.com.

Separate parts from packaging and make sure all parts are accounted for before discarding any packaging material. If any parts are missing, do not begin installation until you obtain the missing parts.

For standard height mounting, do not exceed the recommended 34" distance from the top of the lav deck to the finished floor. To meet ADA requirements, the lav deck cannot exceed the 34" maximum height dimension.



Components



Bowl
Contact your Bradley Representative for color options

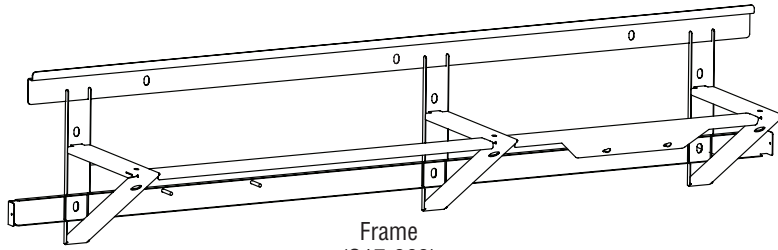

Frame
(S17-363)

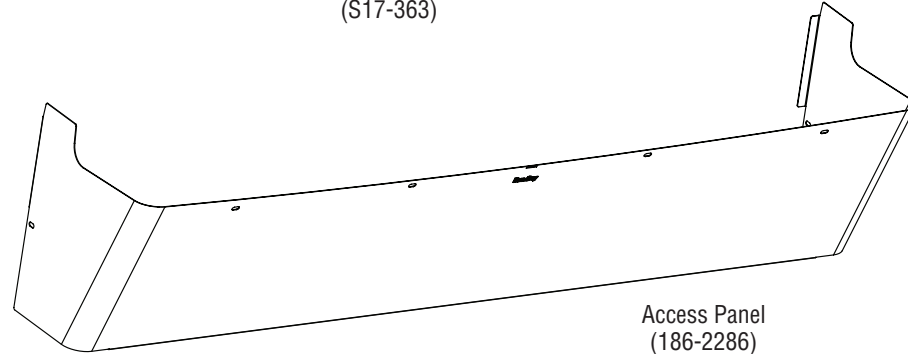



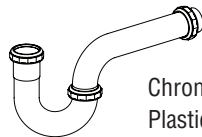

Access Panel
(186-2286)



Chrome P-Trap (S29-094)
Plastic P-Trap (269-1697)

Complete Drain Prepack (S45-2471)

-  **Strainer and Screw (S45-2479)**
-  **O-Ring (125-111)**
-  **Drain Adapter**
-  **Packing Washer**
-  **#10-24 Screw**

Complete Hardware Prepack (S45-2473)

Frame Mounting	Qty.
Washer, Square	9
Washer, Flat 1" O.D.	2
Bowl-To-Frame (S45-2481)	Qty.
Screw, 1/4-20 x 1/2"	3
Washer, Flat 5/8" O.D.	3
Trap Cover (S45-2482)	Qty.
Screw, 10-24 x 1/2"	6
#10 Finishing Washer	6
Trap Hook Bracket	1
Screw, 10-24 x 3/8"	1
Washer, Flat 3/64" O.D.	1

TMV Supply Connections

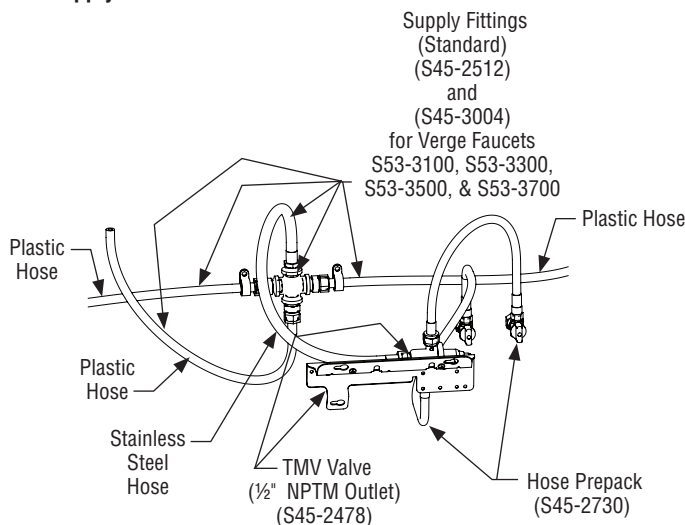

Tempered Supply Connections

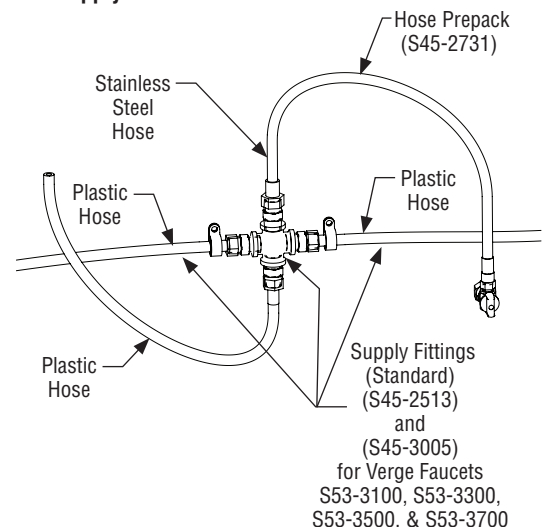

 **Water supply to battery box solenoid MUST be supplied using a plastic hose (provided by Bradley).**

Supplies Required:

- (11) $\frac{3}{8}$ " lag screws, wall anchors, bolts (minimum pull-out rating of 1,000 lb)
- $\frac{1}{2}$ " hot/cold or tempered supply piping
- $1\frac{1}{2}$ " NPT drain piping
- OPTIONAL: (2) 110V GFCI protected electrical outlets for 100–120V AC plug-in transformers (for Bradley Faucets)
- Screen filter(s) as needed, if not included with faucet(s)

Dimensions

(mm)

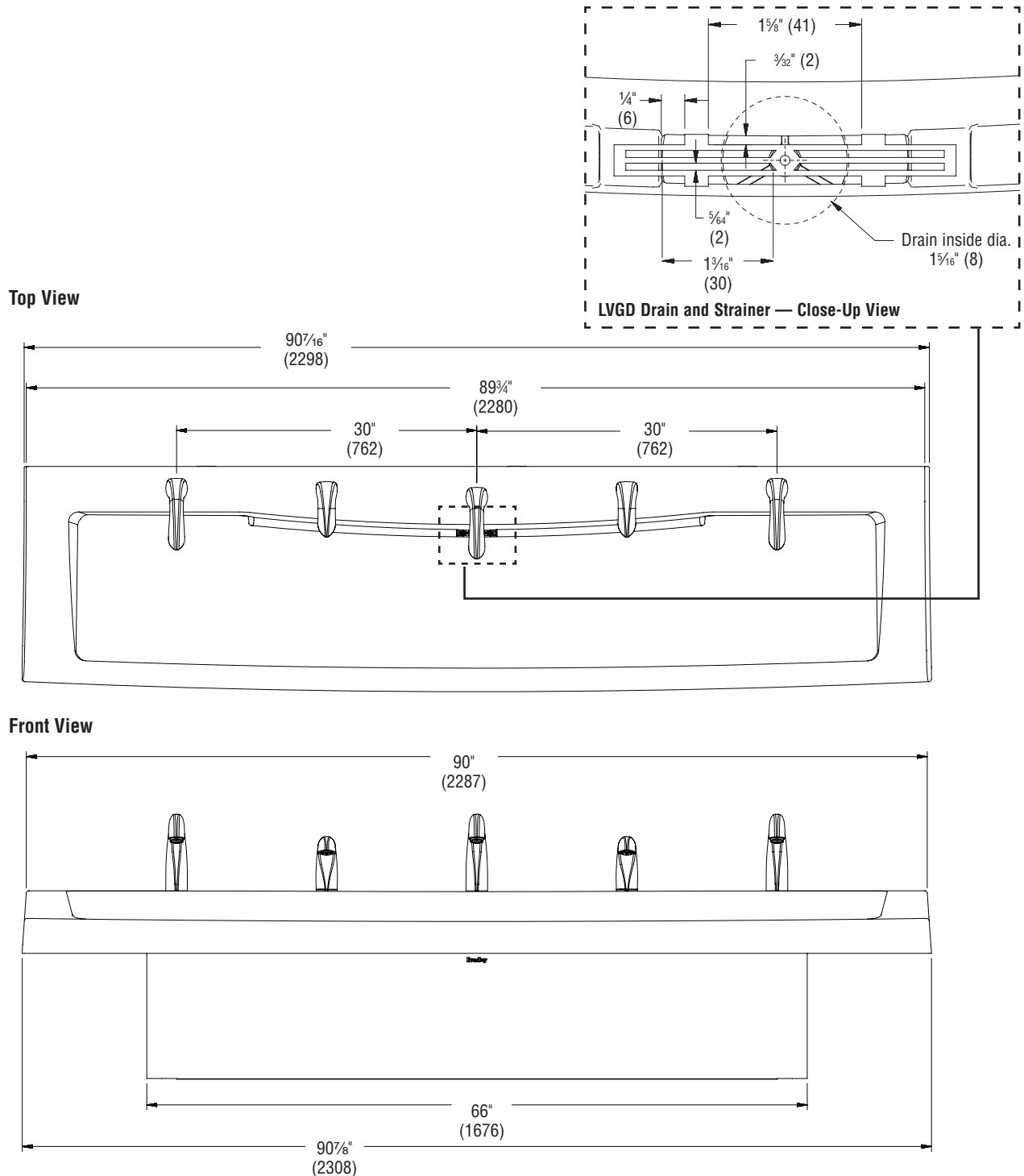

Dimensions – Side View

(mm)

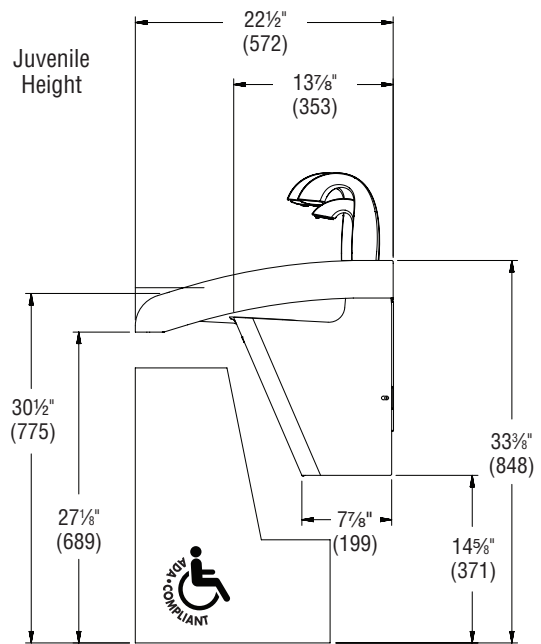
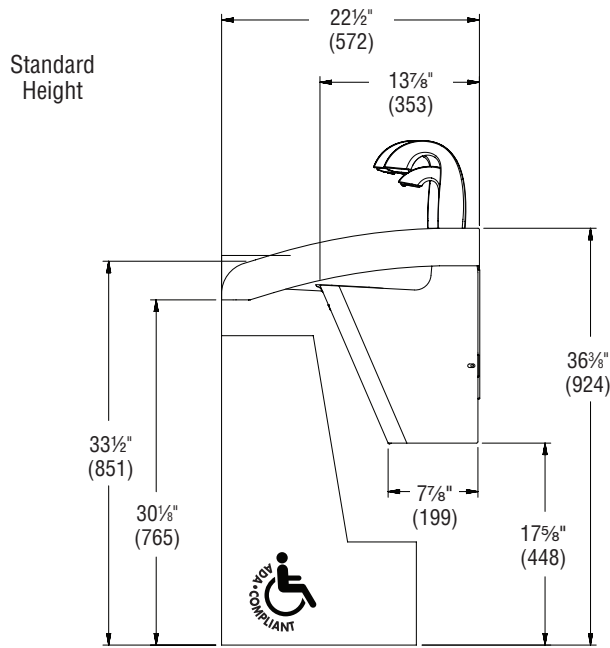

TAS, Pre-K through Grades 5 or 6

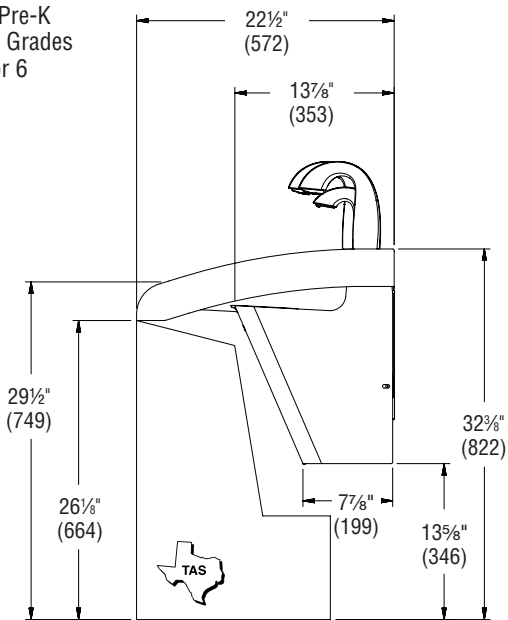

TAS, Grades 6 through 8 or 9

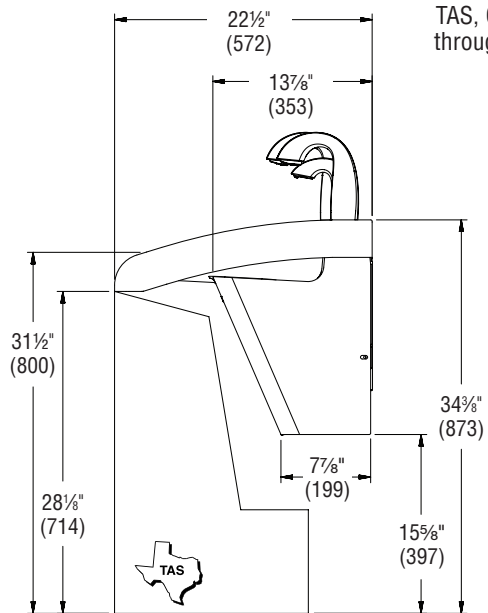

Rough-Ins

(mm)

Standard rough-in shown.

 Reinforce wall at points A and B.

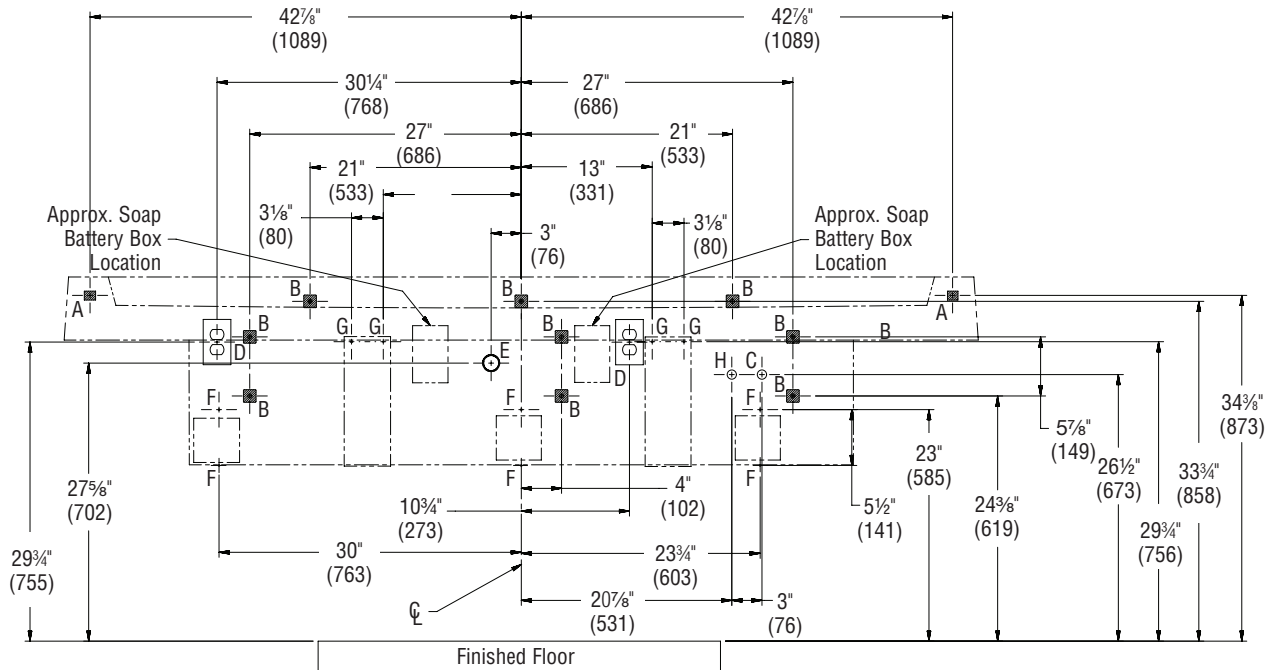

CODE	DESCRIPTION	QTY.
A	3/8" Lav Deck Bowl Anchors with a Minimum Pull-Out Force of 1,000 lb (reinforce walls at anchor points)	2
B	3/8" Lav Deck Frame Anchors with a Minimum Pull-Out Force of 1,000 lb (reinforce walls at anchor points)	9
H, C	1/2" Hot/Cold Supplies, Stub-Out 2" From Wall	1
D	110V GFI Protected Electrical Outlet (AC faucet and soap only)	3
E	1 1/2" NPT Drain, Stub-Out 2" from Wall	1
F	#10 Anchors for Faucet Control Box Installation	4
G	#10 Anchors for Soap Tank Installation	4

RIM HEIGHT	VERTICAL HEIGHT ADJUSTMENTS FOR CODES A-E and H	FIXTURE STYLE
33 1/2"	None	Standard Height
31 1/2"	Subtract 2"	TAS, Grades 6 through 8 or 9
29 1/2"	Subtract 4"	TAS, Pre-K through Grades 5 or 6
30 1/2"	Subtract 3"	Juvenile Height

1 Frame Mounting

Typical installation is shown. It may be necessary to repair the wall after mounting. The fixture may not cover all of the wall modifications.

Plywood Mounting Height	"A" Dimension
Standard Height	20 ⁷ / ₈ " (530mm)
TAS, Grades 6 through 8 or 9	18 ⁷ / ₈ " (479mm)
TAS, Pre-K through Grades 5 or 6	16 ⁷ / ₈ " (429mm)
Juvenile Height	17 ⁷ / ₈ " (454mm)

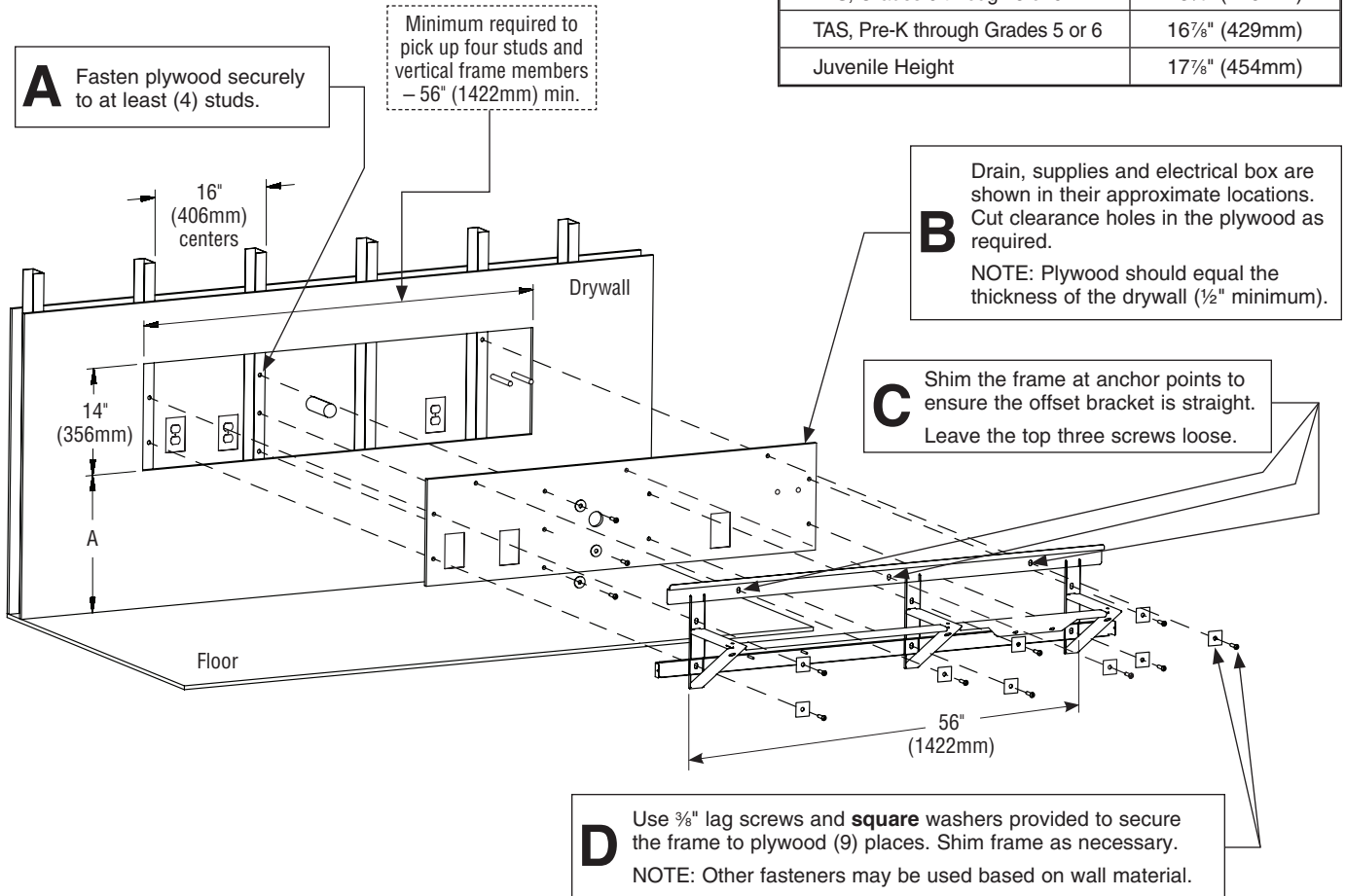

2 Drain Assembly

- For ease of drain installation, lay the bowl on its back.

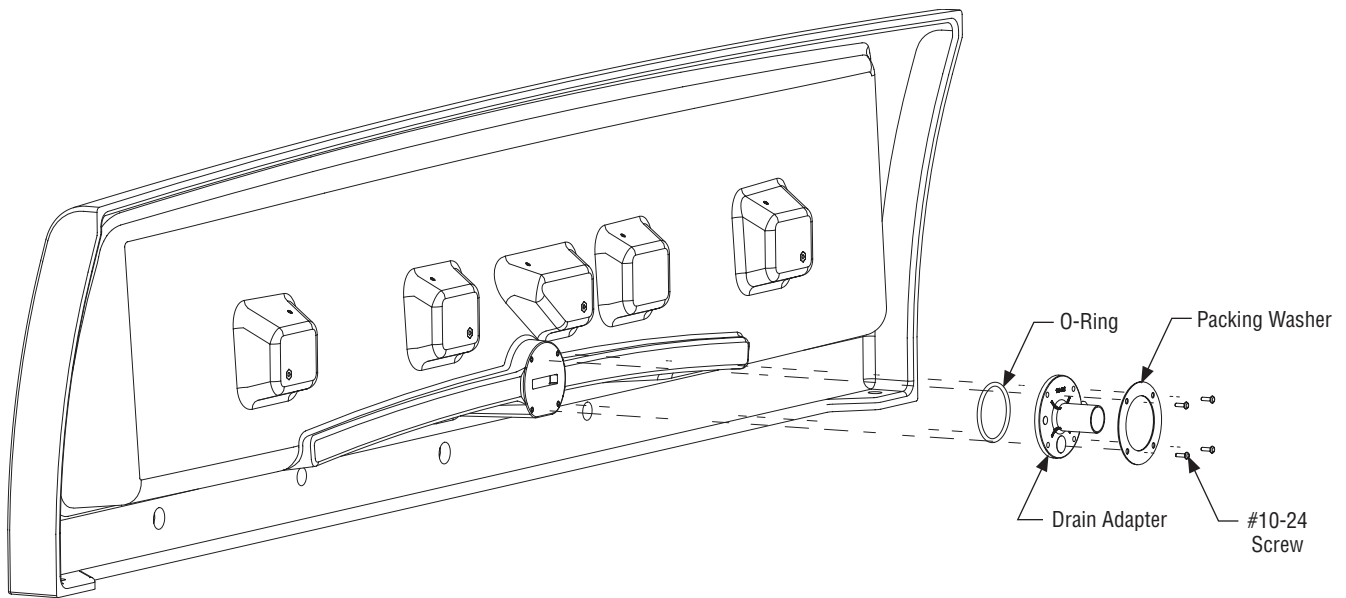

3 Faucets and Optional Soap Valve

- For ease of installation, leave the bowl laying on its back.
See Faucet and Soap installation instructions for assembly.

4a Bowl Mounting (to Frame)

⚠ Water supply to battery box solenoid **MUST** be supplied using a plastic hose (provided by Bradley).

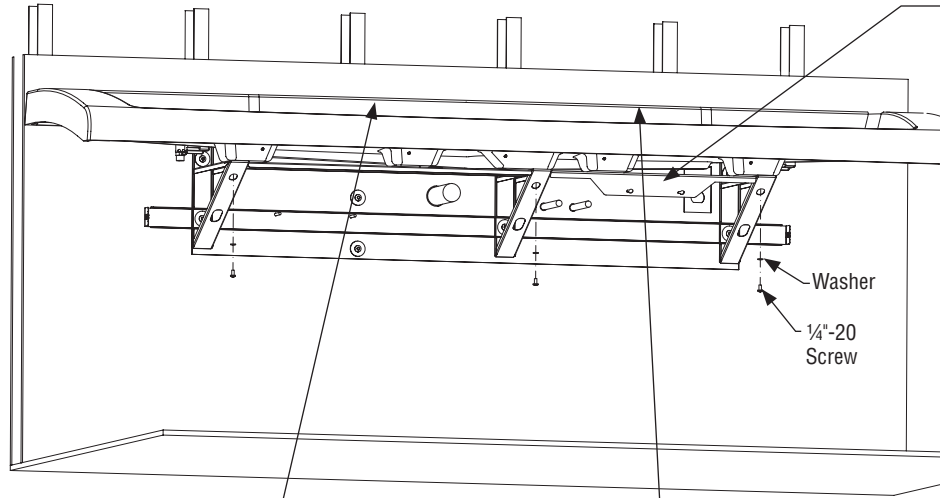

A Press firmly on the back of the bowl to seat the bowl into the frame.
Tighten the top three screws on the frame.

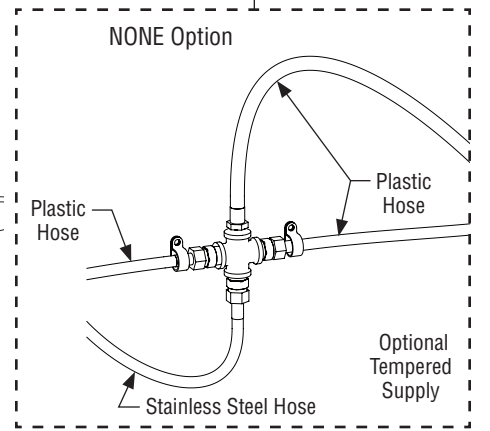
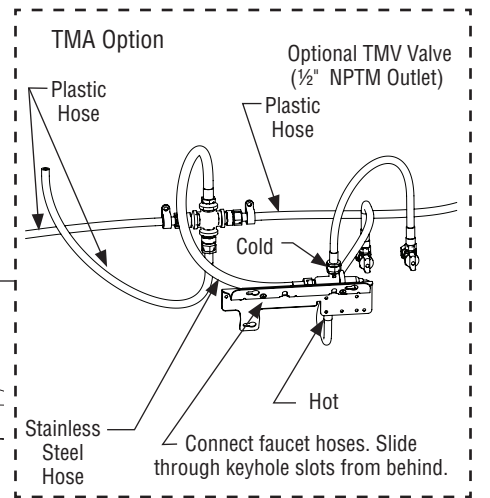

4b Bowl Mounting (to Wall)

⚠ Bowl is heavy!

A Reinforce behind the wall at the two bowl mounting locations, then secure the bowl to the wall.

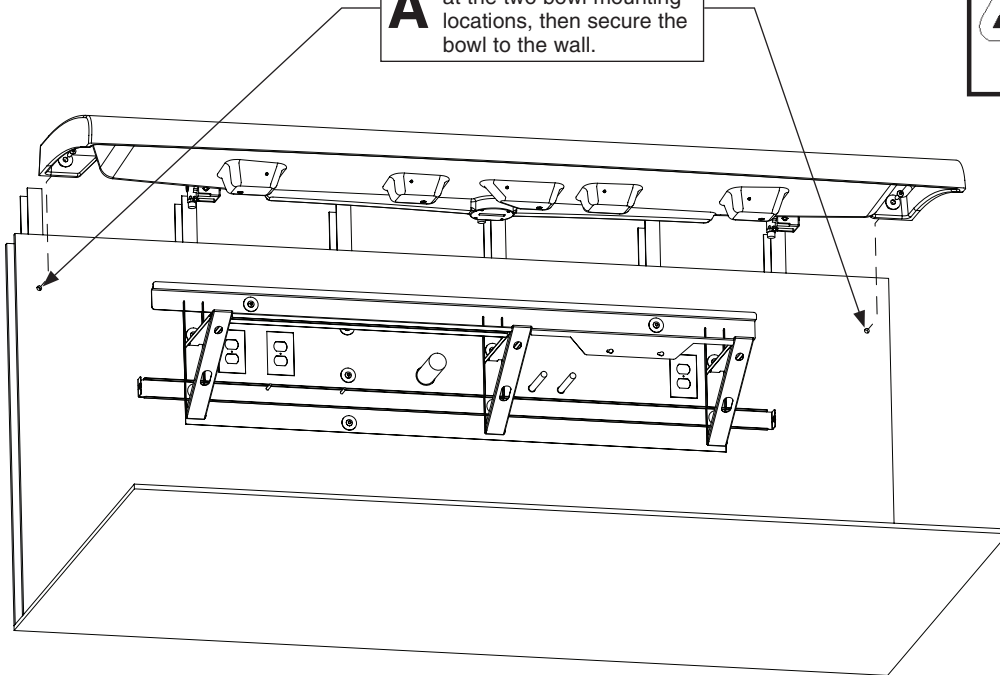

5 Strainer and P-Trap

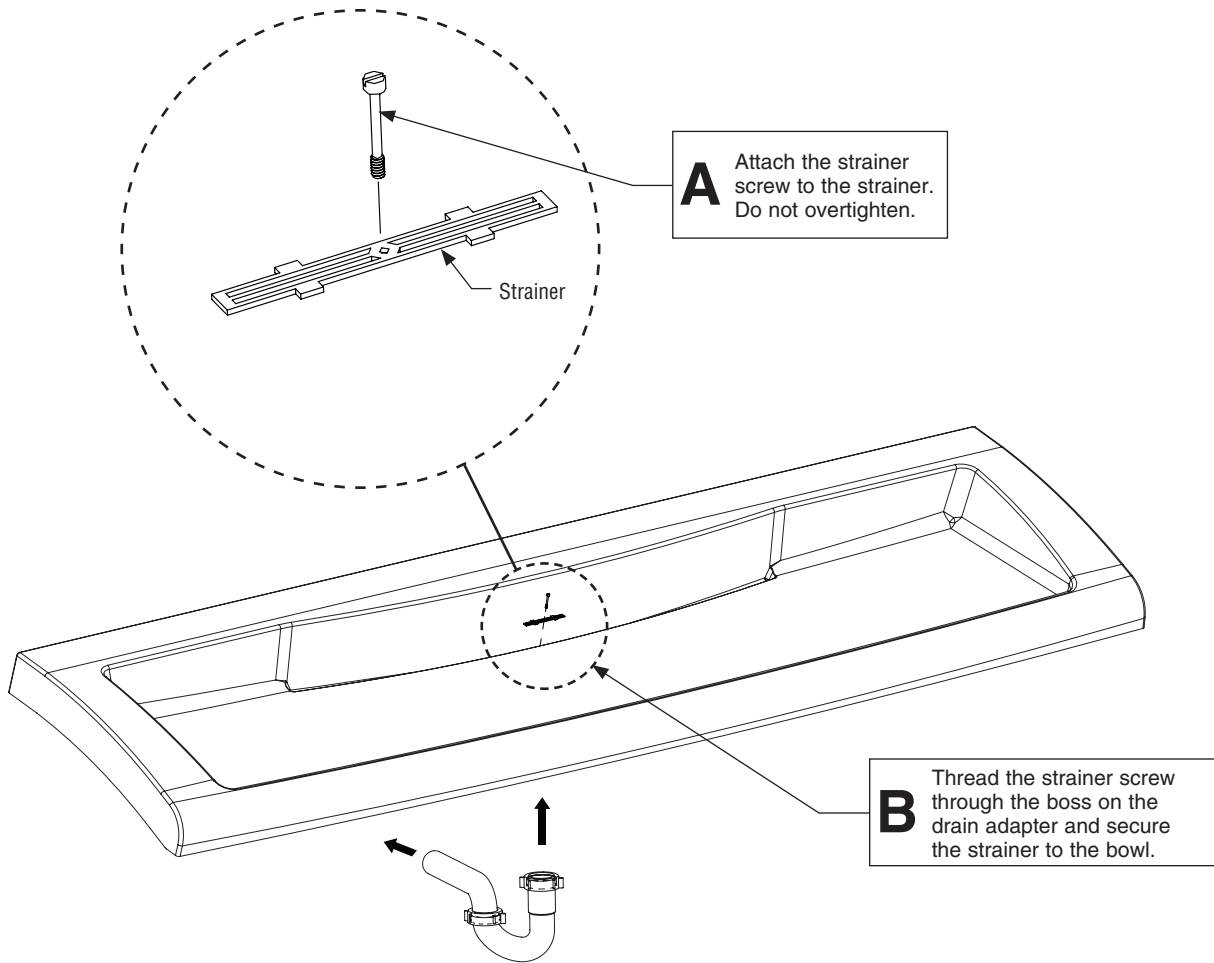

6 Adjust Temperature with Water Running



This valve is NOT factory preset. Upon installation, the temperature of this valve must be checked and adjusted to ensure delivery of a safe water temperature. Water in excess of 110°F (43°C) may cause scalding.

A Loosen Cap Screw about 1/4" (4-6 turns) and lift up cover (do not remove).

B Using cover, turn cartridge gently until desired water temperature is reached. Do not turn past stops as this may damage unit. Push cover down and tighten screw.

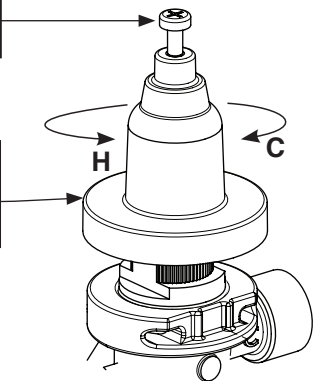

7 Trap Cover

Make all connections before installing trap cover.

A Hang the trap cover onto the hook, then secure the trap cover with the screws provided, starting with the side screws.

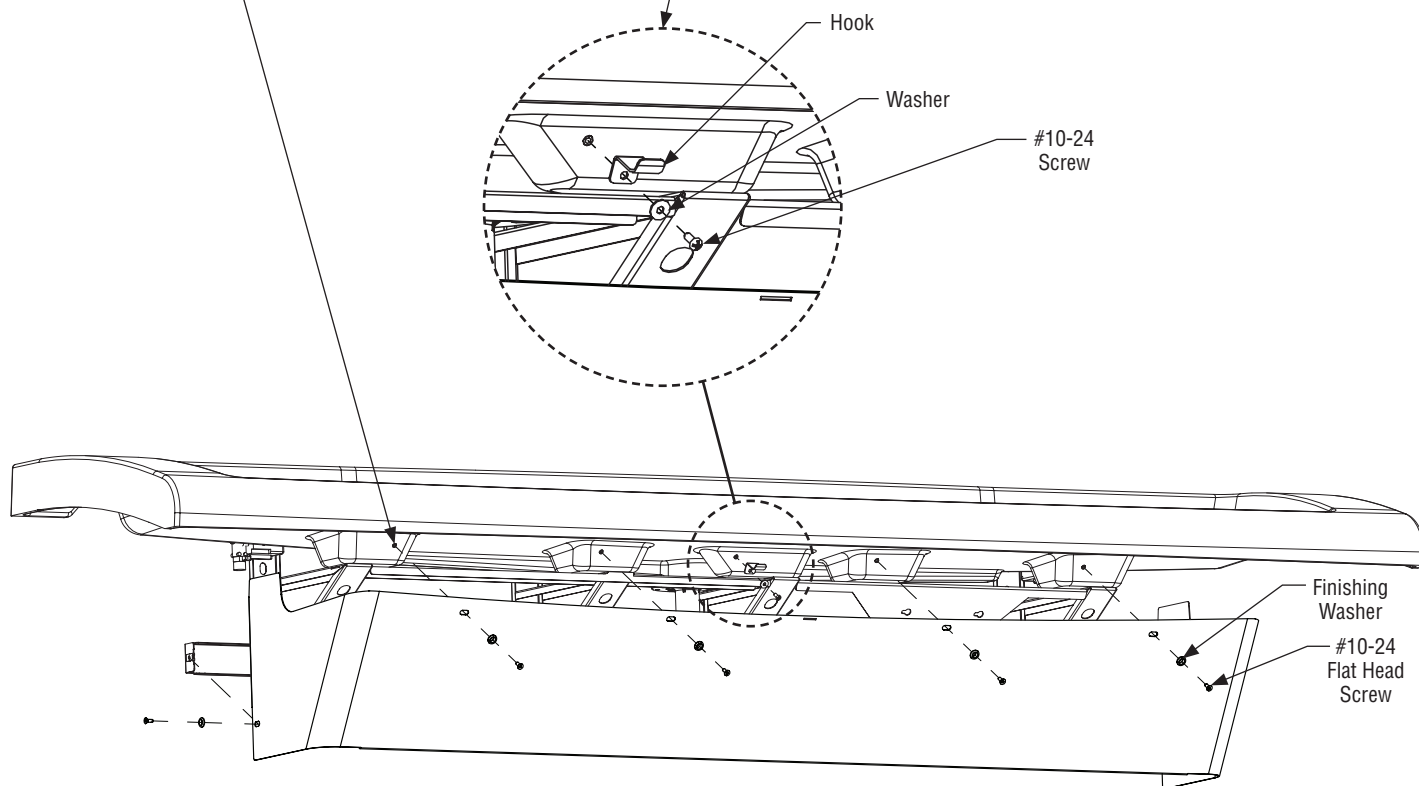

8 Multi-Feed Tank System

See Multi-Feed Tank Installation Instructions for assembly.

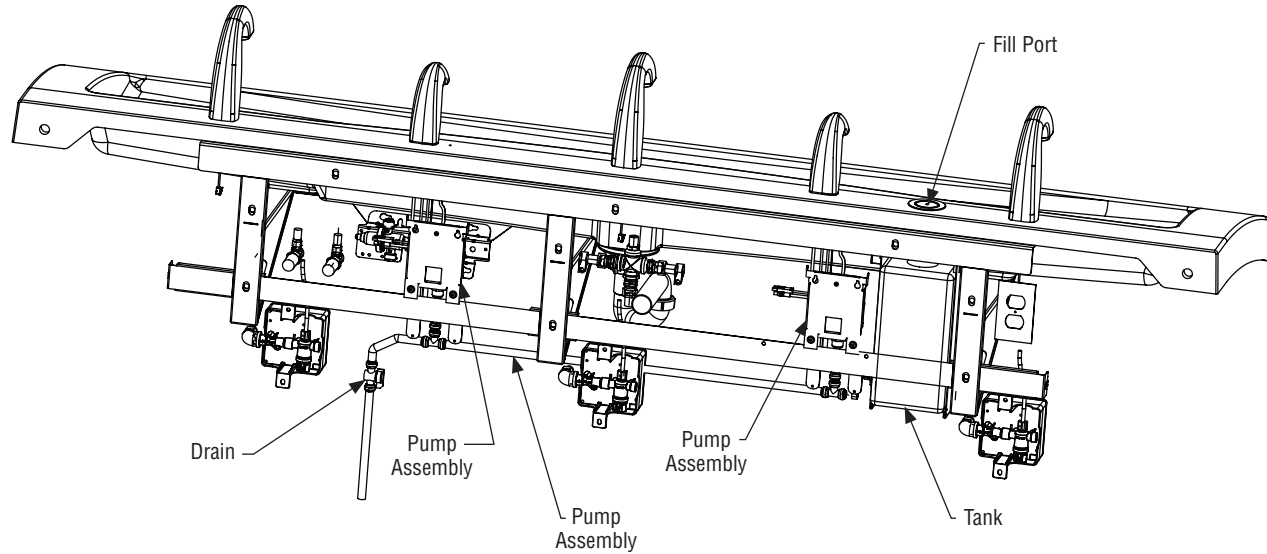
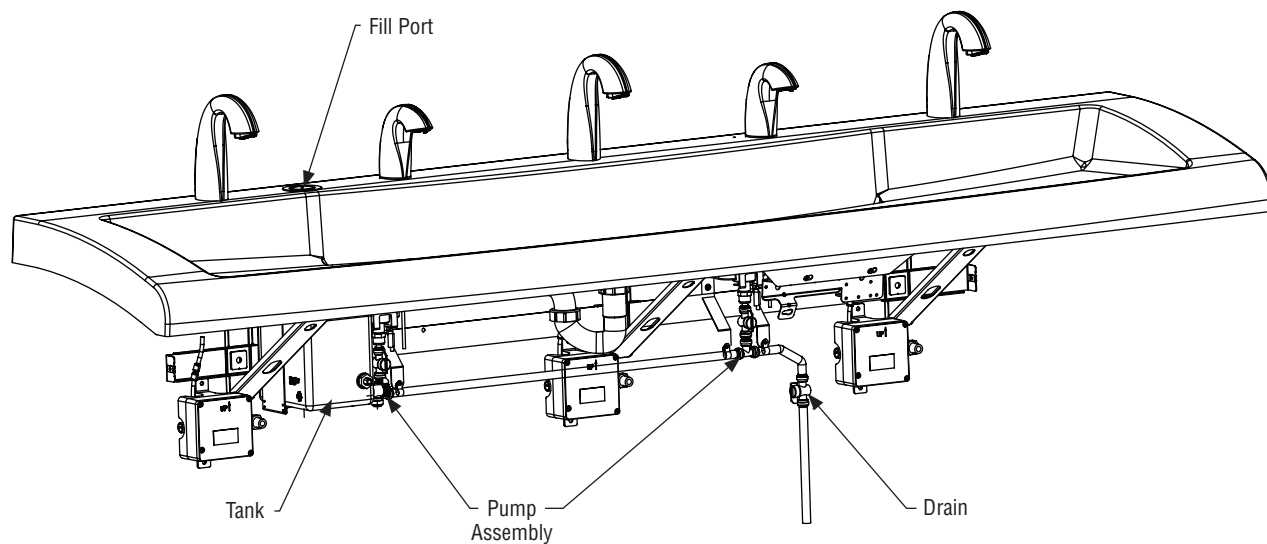

Cleaning and Maintenance for Evero

Material Description: Evero Natural Quartz Material is made from a blend of acrylic modified bio-based polyester resin, natural quartz and other materials and is resistant to chemicals, stains, burns and impact. Surface damage can be easily repaired with everyday cleansers or fine grit abrasives.

Routine Cleaning: For regular cleaning, use standard commercial or household products such as Simple Green®, Creamy Cleanser brand, Formula 409® or Windex®.

Stubborn Stains: Remove tough stains, with non abrasive cleaners and pads such as a white Scotch Brite® pad and Lysol®.

Special Situations for Evero Material

Hard Water Deposits: Remove hard water deposits with a mild solution of vinegar and water. Always rinse the unit thoroughly after cleaning.

Restoring the surface: Refresh and restore the rich surface with one of the following:

Geo Series: Color enhancer such as Tenax® Ager

Pearl Series: Impregnating sealer such as DryTreat Stain - Proof Original™ or Miracle Sealants 511 Impregnator

 **Do not use strong acid or alkaline chemicals and cleansers to clean Evero. If these chemicals come in contact with the surface, wipe them off immediately and rinse with soapy water. Avoid contact with harsh chemicals such as paint remover, bleach, acetone, etc. Avoid contact with hot pans and objects.**

Repair Kits: Evero repair kits are available. Contact your Bradley representative or distributor for part numbers and pricing. Repair kits are made to order and have a shelf life of 30 days.

 *Evero is a unique cast material. Aggregate flow and distribution as well as shades of color can vary from product to product creating natural characteristics.*

Cleaning and Maintenance for Stainless Steel

Material Description: Stainless steel is extremely durable, and maintenance is simple and inexpensive. Proper care, particularly under corrosive conditions, is essential. Always start with the simplest solution and work your way toward the more complicated.

Routine cleaning: Daily or as often as needed use a solution of warm water and soap, detergent, or ammonia. Apply the cleaning solution per the manufacturer's instructions and always use a soft cloth or sponge to avoid damaging the finish.

Stubborn Stains: To remove stains from stainless steel use a stainless steel cleaner and polish such as Ball® stainless steel cleaner or a soft abrasive. Always follow the manufacturer's instructions and apply in the same direction as the polish lines.

 **Never use ordinary steel wool or steel brushes on stainless steel. Always use stainless steel wool or stainless steel brushes.**

Fingerprints and Smears: To remove fingerprints or smears use a high quality stainless steel cleaner and polish in accordance with the manufacturer's instructions. Many of these products leave a protective coating that helps prevent future smears and fingerprints.

Grease and Oil: To remove grease and oil use a quality commercial detergent or caustic cleaner. Apply in accordance to the manufacturer's instructions and in the direction of the polish lines.

Precautions: Avoid prolonged contact with chlorides (bleaches, salts), bromides (sanitizing agents), thiocyanates (pesticides, photography chemicals, and some foods), and iodides on stainless steel equipment, especially if acid conditions exist.

 **Do not permit salty solutions to evaporate and dry on stainless steel.**

The appearance of rust streaks on stainless steel leads to the belief that the stainless steel is rusting. Look for the actual source of the rust in some iron or steel particles which may be touching, but not actually a part of the stainless steel structure.

 *Strongly acidic or caustic cleaners may attack the steel causing a reddish film to appear. The use of these cleaners should be avoided.*

Brand Names

Use of brand names is intended only to indicate a type of cleaner. This does not constitute an endorsement, nor does the omission of any brand name cleaner imply inadequacy. Many products named are regional in distribution, and can be found in local supermarkets, department and hardware stores, or through your cleaning service. It is emphasized that all products should be used in strict accordance with package instructions.